

CBA300 Series Pneumatic Actuators

Improved Design - Compact, Lightweight To Suit All Applications And Environment



BETTIS™

EMERSON™



Emerson is the global leader in valve automation, providing reliable solutions for the most demanding service in the process industry.

CBA300 actuators combine the strength of scotch-yoke actuation cost efficiency and high performance.

Protects against water ingress, adding to the life of the actuator by retarding corrosion.

Suitable for fail-safe service.

Design and Construction

Emerson, a leading pioneer in the valve automation and control industry for more than 55-years, has developed numerous innovations that have become today's industry standards. With continued focus on ingenuity, reliability, quality and product safety, our entire product offering is considered to be the global standard for automating valves in the oil & gas, power generation, pulp and paper, petrochemical and chemical and numerous other process industries. Performance has been the main differentiator. Emerson is recognized for effectiveness and reliability in some of the world's most difficult operating environments.

The Bettis™ CBA300 pneumatic actuator incorporates the most advanced features from a proven history in the scotch-yoke design, assuring operating efficiency and cost-effectiveness. They are lightweight and compact, making them ideally suited for automating virtually any quarter turn (90 degree) rotating mechanism, including ball, butterfly, and plug valves. Economical and requiring little maintenance, these actuators come with a variety of options to meet your demanding valve automation needs.

CBA300 Series Applications And Features

- PED 97/23/EC compliant to meet the stringent requirements of pressure mounting vessels
- Meets both IP66 and IP67M specifications for submergence and severe high pressure water deluge test. This offers superior water ingress and corrosion protection. The actuator has no gaskets and is totally O-ring sealed
- Compatible with NAMUR TopWorx™ mounting configuration allowing it to be internationally accepted and provides the ability to utilize standardized accessories for close coupling or direct mounting on the valve
- Provides models in both spring-return and double-acting configurations. With guaranteed minimum torque outputs ranging from 7,388 lb-in to 20,337 lb-in (835 to 2,333 Nm) in double-acting models. Spring-return models, requiring pressure from only one travel direction, are available for fail clockwise or counterclockwise applications. The spring ending torques range from 2,532 lb-in to 10,457 lb-in (286 to 1,182 Nm)
- Scotch yoke design provides optimum torque curves for quarter-turn operation
- Light weight, easy installation, and compact for tight piping configurations
- Increased actuator efficiency and corrosion resistance are possible with a Xylan fluoropolymer coating on the interior of the power cylinder. Permanently bonded coating is highly resistant to abrasion, thermal shock and provides excellent lubricity and low friction properties
- Ductile iron housing and piston provide more strength per pound, increased durability and corrosion resistance. The pressure vessel quality housing is approved for use by ASME and the Pressure Equipment Directive (PED 97/23/EC)
- Close Loop Instrument System for actuators **should always be used** for the following applications: high humidity, salt air, corrosive dust, inks and dyes and wash downs. The closed loop system routes the operating media being exhausted from the power side of the cylinder to the vented side of the cylinder. Maximum pressure on the vented side of the power cylinder is to be 5 to 8 psig
- 5-year warranty

Operating Principle

CBA300 double-acting and single-acting (spring-return) pneumatic actuators are designed in such a way that there are no moving parts on the outside (with the exception of the position indicator) making them safe, easy to install and virtually maintenance free.

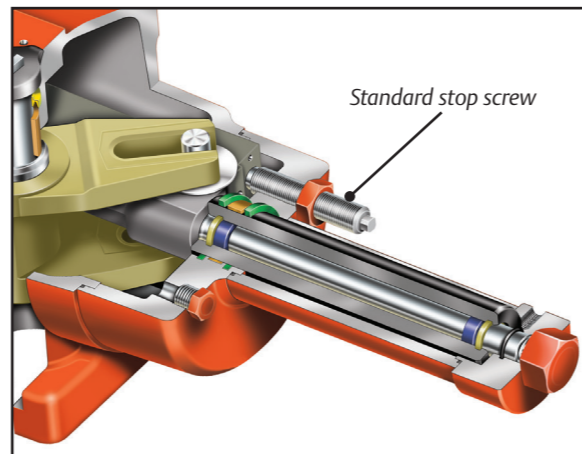

M11 Hydraulic Override Configuration

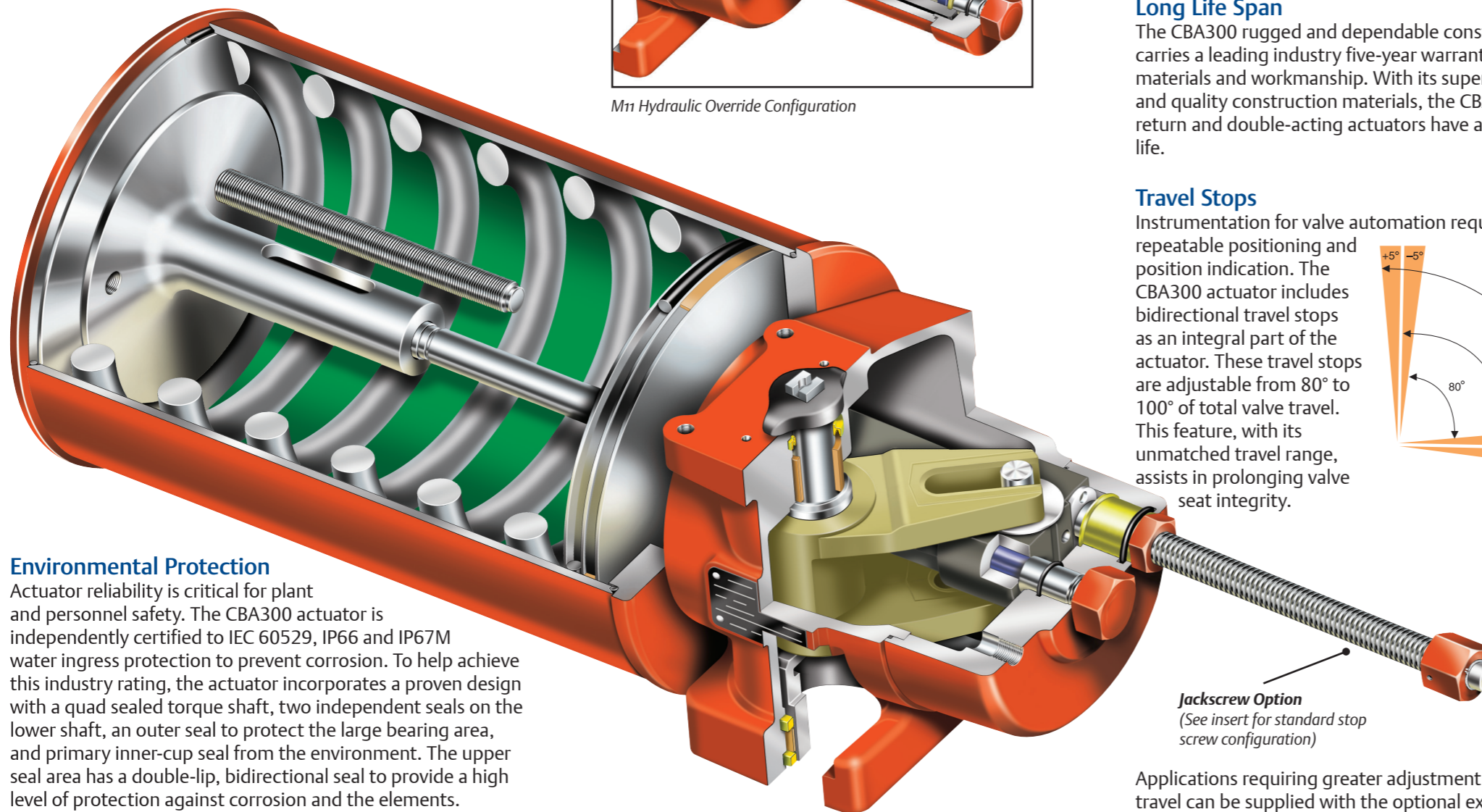

Environmental Protection

Actuator reliability is critical for plant and personnel safety. The CBA300 actuator is independently certified to IEC 60529, IP66 and IP67M water ingress protection to prevent corrosion. To help achieve this industry rating, the actuator incorporates a proven design with a quad sealed torque shaft, two independent seals on the lower shaft, an outer seal to protect the large bearing area, and primary inner-cup seal from the environment. The upper seal area has a double-lip, bidirectional seal to provide a high level of protection against corrosion and the elements.

Extreme temperatures require different solutions to maintain peak operational integrity and reliability. The CBA300 actuator is available in three different temperature trims:

- Standard trim is suitable for -20°F to +200°F (-29°C to +93°C)
- Optional high temperature trim allows operation from 0°F to +350°F (-18°C to +177°C)
- Special non-PED low temperature trim 40°F to +150°F (-40°C to +66°C)
- Factory built or upgrades available
- Pneumatic operating pressures range from 40 to 150 psig (3 to 10 bar)

High Performance Springs

CBA300 actuators have high strength and performance alloy carbon steel springs, protected by Tactyl 50, a pliable self-healing coating. The spring further extends with the shot peening of the springs during manufacture, and additional step that further differentiates its quality from others.

Override Options

Override modules used to reposition a valve and provide full rated torque in the event of a power loss can be supplied with a jackscrew and hex nut adaptor or a jackscrew with hand wheel. CBA300 actuators come with a blowout-proof jackscrew that absorbs impact loads at maximum recommended actuator speeds. Double-acting models can be supplied with one or two jackscrews. The M11 hydraulic override is also available.

Long Life Span

The CBA300 rugged and dependable construction carries a leading industry five-year warranty on both materials and workmanship. With its superior design and quality construction materials, the CBA300 spring-return and double-acting actuators have a long service life.

Travel Stops

Instrumentation for valve automation requires repeatable positioning and position indication. The CBA300 actuator includes bidirectional travel stops as an integral part of the actuator. These travel stops are adjustable from 80° to 100° of total valve travel. This feature, with its unmatched travel range, assists in prolonging valve seat integrity.

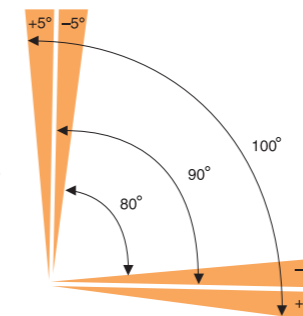

Jackscrew Option
(See insert for standard stop screw configuration)

Applications requiring greater adjustment of valve travel can be supplied with the optional extended travel stops for full valve stroke travel adjustment and use as a lockout device. Consult the factory for this option.

Safety Integrity Level (SIL)

CBA300 actuators are suitable for use within the demanding applications of a SIL environment. These actuators have a Failure Modes and Effects Diagnostics Analysis (FMEDA) capability with reporting performed through Exida.com™ for SIL suitability. They can be combined with other SIL-rated components such as solenoid valves, switches, and regulators. When a Fisher, TÜV-certified FIELDVUE® controller is added to the CBA300, it is capable of partial stroke testing and providing continuous monitoring of supply pressure, valve position and pressure values to verify proper working condition. The CBA300 then becomes an integral component in controlling the final control element in SIL 1, 2 or 3 applications.

Efficient Bearing Design

Bearings assist in enhancing the life cycle of the actuators by providing smooth and consistent torque output. The CBA300 actuator pistons have three field replaceable bearings. In addition, the actuator features PTFE-coated upper and lower torque shaft bearings for wear resistance and is easily maintained in the field.



Emerson WACC provides actuators for specialty applications such as fire-retardant coatings and treatments

Actuator / Accessory Interfaces

Standards and Certifications

Bettis CBA300 pneumatic actuators are manufactured to meet the following worldwide quality and safety standards:



ISO-9001



ABS

PED/97/23/EC –
Pressure
Equipment
Directive



**Bettis CBA300
with Topworx Positioner**



**Bettis CBA300
with Wireless Transmitter**

Valve Automated Packages

Emerson offers a complete valve operating system as a solution for final valve control. Combining the CBA300 actuator and controls with the selected valve into a single system at any of our international Actuation Technologies World Automation Configuration Centers (WACC) – are perfect for large international projects.

Through the use of our global Actuation Technologies World Automation Configuration Centers, Emerson can integrate its products with a complete offering of control options, including world-class PlantWeb® digital plant architecture and the entire range of automation solutions.

Supporting our Actuation Technologies, Emerson has pre-engineered and documented a series of commonly required and approved control system that will reduce lead times, simplify purchasing, installation and start-up.

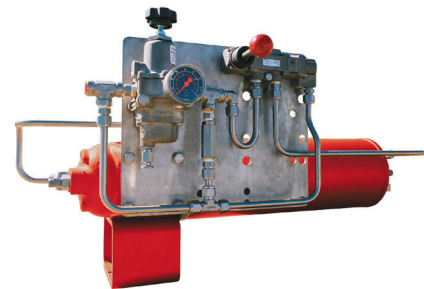
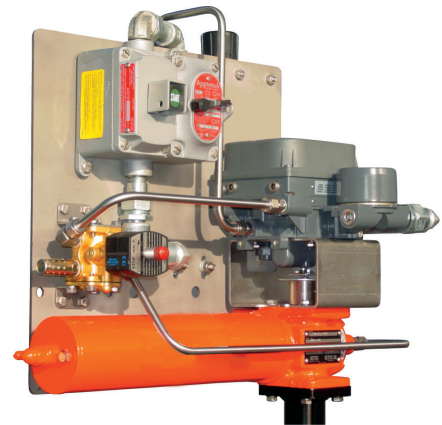

Other Emerson controls and accessories:

Fisher™

- Digital Valve Controllers
- Positioners
- Regulators

TopWorx™

- Switch Boxes
- Wireless Position Monitoring

ASCO Numatics™

- Solenoid Valves

This product is only intended for use in large-scale fixed installations excluded from the scope of Directive 2011/65/EU on the restriction of the use of certain hazardous substances in electrical and electronic equipment (RoHS 2).