

Valvetop DXP

502.969.8000

Flame Proof - Explosion Proof - Intrinsically Safe



Valvetop DXP

The Valvetop DXP discrete valve controller combines bus networking, pilot valve and position sensors into a single, globally certified, explosion proof enclosure that attaches to any automated valve package.

Features: Zone 0 Intrinsically Safe
Zone 1 Flameproof/Explosion Proof
Tropicalized Aluminum Enclosure

Options: GO Switch Leverless Limit Switches
FOUNDATION Fieldbus
AS-Interface
DeviceNet
4-20mA Position Transmitter
HART Protocol
Proximity Switches
Mechanical Switches



DeviceNet

HART
COMMUNICATION PROTOCOL



FAST TRACK DELIVERY

DXP-L21G_EB
(2) GO Switches
Explosion Proof

DXP-AS1G_EB
AS-Interface
Explosion Proof

DXP-L21G_EB1A2
(2) GO Switches
Explosion Proof
24VDC 5/4 Aluminum
pilot valve

DXP-0XG1_EB
4-20 mA Transmitter
Explosion Proof

DXP-FFC1G_EBPA2
FOUNDATION Fieldbus
Exp. Proof or Intr. Safe
5/4 Aluminum pilot valve

DXP-DN11G_EB1A2
DeviceNet
Explosion Proof
5/4 Aluminum pilot valve

DXP-AS1G_EB1A2
AS-Interface
Explosion Proof
5/4 Aluminum pilot valve

DXP-DN1G_EB
DeviceNet
Explosion Proof

DXP-M21G_EB
(2) Mechanical Switches
Explosion Proof

For Area Class, choose 0 (I.S. or 1 (Exp. Proof)
 For Shaft, choose S or N (both in stock)

Enclosure



DXP

Enclosure: Die-cast, aluminum; Epoxy-coated O-Ring sealed

Coating: Tropicalized inside and out

Cover bolts: 6 stainless steel captive cover bolts

Terminal Strip: Standard 12 pt. molded nylon

Temperature Rating: Determined by internal components - Consult Factory

Environment: Built to last in the most demanding applications

Ordering Guide

Fill in the boxes to create your 'ordering number.'

Bus/Sensor

Bus Network

- AS** AS-Interface
- FF** FOUNDATION Fieldbus (Pilot P, R, or U only)
- DN** DeviceNet

Partial Stroke Test

- ES** ESD/PST Module with GO Switch

GO Switches (SPDT hermetic seal)

- L2** (2) GO Switches
- L4** (4) GO Switches

Mechanical Switches

(Area Class 1, C, B, or W)

- M2** (2) Mech SPDT
- M4** (4) Mech SPDT
- M6** (6) Mech SPDT
- T2** (2) Mech DPDT
- K2** (2) Mech SPDT gold contacts
- K4** (4) Mech SPDT gold contacts

Proximity Switches

- PS** (2) hermetically sealed proximity switch module w/BriteLite LED indication
- PN** (2) hermetically sealed proximity switch module

Inductive NAMUR Sensors

- E2** (2) p+f NJ2+V3-N
- E4** (4) p+f NJ2+V3-N

Analog Output (Available with 2-switch options only for L, M, K, E, T)

- _X** 4-20mA transmitter
- _H** 4-20mA transmitter with HART

Examples:

- LX** =(2) GO Switches with transmitter
- OX** =4-20mA transmitter no switches
- LH** =(2) GO Switches with HART transmitter

Classification



0 Intrinsically Safe* (Bus/Sensor must be FF, L, PN, E, or _H)
Class I Div 1 & 2, Groups A-D
Zone 0 (ATEX/IEEx ia IIC II1G IP67; Type 4, 4X

1 Flame Proof/Explosion Proof

Class I Div 1-2, Groups C-D
Class I Div 2, Groups A-D (Groups A & B must be hermetically sealed)
Zone 1, (ATEX/IECEX)
Ex/EEEx d IIB+H2 II2G IP67; Type 4, 4X, 7

2 Non-Incendive (Not available for Sensor options M, T, or K)

Class I Div 2, Groups A-D
Class II Div 2, Groups E-G
Zone 2 (ATEX/IECEX)
Ex/EEEx nC tD II3GD IP67; Type 4, 4X

C (ATEX/IECEX)

Ex/EEEx d IIC II2G IP67

B INMETRO (Brasil)

W IP67/No approvals

* With appropriate I.S. barrier



Visual Display

Visual Display: Impact resistant polycarbonate; O-ring sealed; 360° adjustable



G Standard 90°
Green OPEN,
Red CLOSED

B 90° Black OPEN,
Yellow CLOSED

4 45° Green OPEN,
Red CLOSED

X 45° Black OPEN,
Yellow CLOSED

Y 90° Yellow OPEN,
Black CLOSED

1 3 way, 90°



3 3 way, 90°



5 3 way, 90°



7 3 way, 180°



9 3 way, 180°



Shaft

Shaft: Stainless steel;
O-ring sealed

Shaft Retainer:
Stainless steel



S 1/4" DD
304 Stainless Steel



N NAMUR
304 stainless steel

Enclosure

DXP

Bus/Sensor

Classification

Visual Display

Shaft

Dimensions

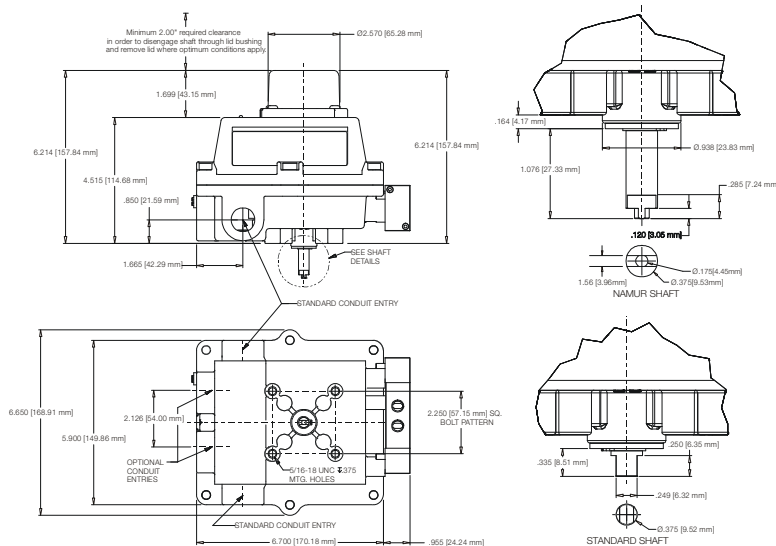

Conduit Entries	O-Rings	Pilot	Spool Valve	Valve Cv	Manual Override
<ul style="list-style-type: none"> <input checked="" type="checkbox"/> E (2) 3/4" NPT 4 (2) 3/4" NPT (2) 1/2" NPT M (2) M20 3 (4) M20 6 (4) 3/4" NPT 	<ul style="list-style-type: none"> <input checked="" type="checkbox"/> B Buna N E EPDM S Silicone V Viton 	<p>Blank No pilot device(s)</p> <ul style="list-style-type: none"> <input checked="" type="checkbox"/> 1 (1) 24 Vdc pilot, .5W, fail open/closed 2 (2) 24 Vdc pilots, .5W, fail last position 3 (2) 24 Vdc pilots, .5W, block center 4 (1) 220 Vac pilot, 1.9W, fail open/closed 5 (2) 220 Vac pilots, 1.9W, fail last position 6 (2) 220 Vac pilots, 1.9W, block center 7 (1) 110 Vac pilot, 1.1W, fail open/closed 8 (2) 110 Vac pilots, 1.1W, fail last position 9 (2) 110 Vac pilots, 1.1W, block center P (1) piezo pilot, fail open/closed (FF only) R (2) piezo pilots, fail last position (FF only) U (2) piezo pilots, block center (FF only) 	<p>Blank No spool valve</p> <ul style="list-style-type: none"> <input checked="" type="checkbox"/> A Aluminum Hard coat anodized S 304 Stainless steel 6 316 Stainless steel 	<p>Blank No spool valve</p> <ul style="list-style-type: none"> <input checked="" type="checkbox"/> 2 1.2 Cv (1/4" NPT Ports) 3 3.0 Cv (1/2" NPT Ports) (Spool Valve A only) C Cold temperature valve to -50°C 1.0 Cv (1/4" NPT Ports) (Sensor L2; O-Ring E or S only) (Spool Valve must be S or 6) 	<p>Blank No spool valve</p> <ul style="list-style-type: none"> 1 Single Pushbutton Momentary/Latching 2 Dual Pushbutton Momentary/Latching 3 Single Pushbutton Momentary 4 Dual Pushbutton Momentary 5 Manual Reset No voltage release latching with pushbutton (Spool Valve 6 only) A Single palm actuator Momentary/Latching B Dual palm actuator Momentary/Latching C Single palm actuator Momentary D Dual palm actuator Momentary E Manual Reset No voltage release latching with palm actuator (Spool Valve 6 only) T Partial stroke test button with lockable cover (Sensor ES only) (Conduit Entries 4 or 3 only)

Conduit Entries
 O-Rings
 Pilot
 Spool Valve
 Valve Cv
 Manual Override